



AUTOMIZER RIGHT-HAND™

PRODUCTIVITY REQUIRES A STRONG ARM WITH A LONG REACH

- 15 yd³ to 37yd³ body sizes available
- Up to 850 lbs/yd³ compaction
- 50/50, 40/60 or 60/40 split body configurations available for dual collection
- Single piece body walls for increased strength and seamless appearance
- Best in class Right Hand™ Arm with 12 foot reach and 1000 lb lifting capacity. (95 and 300 gal. available)
- In-line arm design combined with a large 6.5yd³ hopper for smooth, low dumping and effortless maneuverability
- Tapered body for improved compaction and easy unloading
- Ejection system: Tip-to-dump or Full Eject available
- Multiplex Electrical System with Onboard Diagnostic tools for easy troubleshooting
- Fully integrated Labrie CNG systems - roof, tailgate and back of cab mount - 50 to 100 DGE available

Body Specifications

Body Floor	0.157" AR450 175,000psi
Body Sides (lower)	10ga A1011 80,000psi
Body Roof	12ga A1011 80,000psi
Tailgate	12ga A1011 80,000psi

Hopper Specifications

Hopper Size (yd ³)	6.5
Hopper Floor	1/4" AR450 175,000psi
Hopper Sides (lower)	1/4" AR450 175,000psi

Cylinder Specifications

Body Lifting Cylinder (15yd ³ bodies)	4 stages 6-1/16" bore x 132" stroke
Body Lifting Cylinder (20yd ³ bodies)	4 stages 6-1/16" bore x 150" stroke
Body Lifting Cylinder (27-31yd ³ bodies)	4 stages 6-1/16" bore x 180" stroke
Packer Cylinders	4" bore x 2-1/2" rod x 40" stroke
Tailgate Cylinders	2-1/2" bore x 1-3/4" rod x 39" stroke
Arm Extension Cylinders	1-1/2" bore x 1" rod x 52-15/16" stroke
Lifting Cylinder	3" bore x 1-1/2" rod x 16" stroke
Grabber Cylinders	1-1/2" bore x 1" rod x 4-15/16" stroke

Hydraulic Specifications

Pump Make & Model	Dual Vane
Pump Capacity	BODY: 20.4 gpm@700 rpm; ARM: 16.3 gpm@700 rpm
Max. Operating Pressure	3,000 psi (2,000 psi on single axle chassis)
Oil Reservoir	94 gal

Arm Specifications

Arm Lift Capacity	1,000 lbs
Arm Reach	144"
Swing out	36"
Arm Controls	Proportional joystick, electric over hydraulic

Packer Specifications

Compaction ratio (lbs/yd ³)	850 (650 on single axle chassis)
Packer Panel Face Plate	1/4" 100QT 100,000psi
Packer Width	64-1/2"
Packer Height	24"
Packer Stroke	52"

Note: Specifications subject to change without notice





AUTOMIZER RIGHT-HAND™

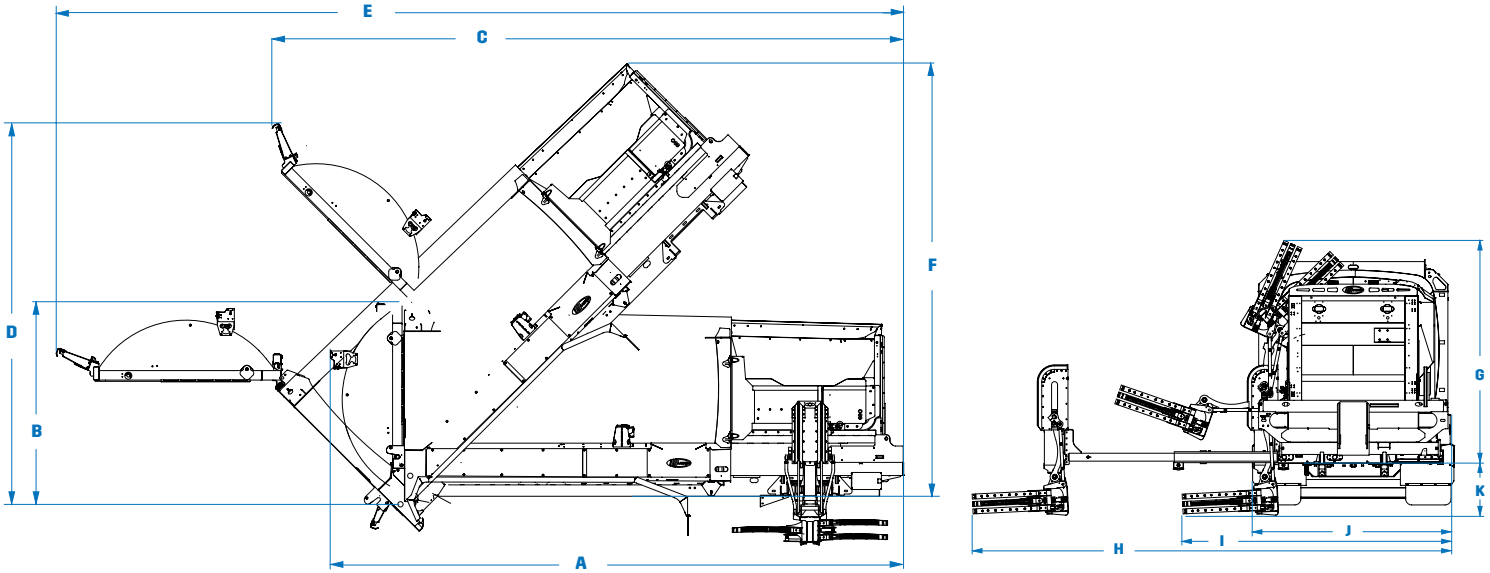

Body Dimensions	15yd ³	17yd ³	19yd ³	21yd ³	20yd ³	22yd ³	24yd ³	26yd ³	27yd ³	29yd ³	31yd ³	33yd ³	31yd ³	33yd ³	35v ³	37yd ³
	(15+0)	(15+2)	(15+4)	(15+6)	(20+0)	(20+2)	(20+4)	(20+6)	(27+0)	(27+2)	(27+4)	(27+6)	(31+0)	(31+2)	(31+4)	(31+6)
A. Overall Length, Tailgate Closed (in.)	216	222	235	250	244	250	263	278	284	290	303	318	314	320	333	348
Overall Width (in.)	102	102	102	102	102	102	102	102	102	102	102	102	102	102	102	102
B. Overall Height Above Frame, Tailgate Closed (in.)	103	103	103	103	103	103	103	103	103	103	103	103	103	103	103	103
C. Overall Length, Tailgate Open (in.)	266	266	266	266	294	294	294	294	334	334	334	334	364	364	364	364
D. Overall Height Above Frame, Tailgate Open (in.)	197	197	197	197	197	197	197	197	197	197	197	197	197	197	197	197
E. Overall Length, Dumping Position (in.)	380	380	380	380	408	408	408	408	447	447	447	447	474	474	474	474
F. Overall Height Above Frame, Dumping Position (in.)	182	182	182	182	201	201	201	201	228	228	228	228	242	242	242	242
G. Overall Height Above Frame When Dumping (in.)	113	113	113	113	113	113	113	113	113	113	113	113	113	113	113	113
H. Overall Width, Arm Out, Grabber Closed (in.)	243	243	243	243	243	243	243	243	243	243	243	243	243	243	243	243
I. Overall Width, Arm In, Grabber Closed (in.)	137	137	137	137	137	137	137	137	137	137	137	137	137	137	137	137
J. Overall Width, Arm In, Grabber Open (in.)	101	101	101	101	101	101	101	101	101	101	101	101	101	101	101	101
K. Distance between bottom of Grabber and chassis frame rail (in.)	25	25	25	25	25	25	25	25	25	25	25	25	25	25	25	25

Performance Specifications

Arm In (96" reach)	2.0 sec @ 700 rpm
Arm In (144" reach)	3.0 sec @ 700 rpm
Arm Out (96" reach)	2.2 sec @ 700 rpm
Arm Out (144" reach)	3.3 sec @ 700 rpm
Arm Up	3.0 - 3.6 sec @ 700 rpm
Arm Down	2.5 - 3.0 sec @ 700 rpm
Grabber Open	1.5 - 2.0 sec @ 700 rpm
Grabber Close	1.5 - 2.0 sec @ 700 rpm

Packer complete cycle without regeneration	12 sec @ 1200 rpm
Packer complete cycle with regeneration	14 sec @ 700 rpm
Tailgate Open	21 sec @ 700 rpm
Tailgate Close (with Safety Flow limiter)	26 sec @ 700 rpm
Body Up (depending on body size)	34-44 sec @ 700 rpm
Body Down (depending on body size)	18-25 sec @ 700 rpm
Crusher panel Up	5 sec @ 700 rpm
Crusher panel Down	4 sec @ 700 rpm
Hydraulic chute to curb side	3 sec @ 700 rpm
Hydraulic chute to street side	4 sec @ 700 rpm



labriepius
SERVICE & PARTS

www.labrietrucks.com

DRIVE EXCELLENCE

labrie

sales@labriegrup.com • 1-800-463-6638